

Switching Power Supply Type PSS 480W DIN rail mounting



- Universal AC single phase input full range
- Can also be used as bi-phase 400VAC
- Installation on DIN rail 7.5 or 15mm
- PFC as standard
- High efficiency up to 90%
- Power ready output
- Parallel connection feature
- Compact dimensions
- CE, TÜV, CCC approved and cULus listed

Product Description

The Switching power application where the supplies SPD series are specially designed to be used in all automation and performance are a must.

Ordering Key

SP D 24 480 B

Model _____
 Mounting (D = Din rail) _____
 Output voltage _____
 Output power _____
 Input Type _____

Input type: 1= single phase

Approvals



Optional Features

Description	Code
Plug-in connectors	B

Output Performances

MODEL NO.	INPUT VOLTAGE	OUTPUT WATTAGE	OUTPUT VOLTAGE	OUTPUT CURRENT	EFF. (min.)	EFF. (typ.)
Single Output Models						
SPD24	90~264 VAC	480 WATTS	+ 24 VDC	20 A	86%	89%
SPD48	90~264 VAC	480 WATTS	+ 48 VDC	10 A	87%	90%

¹⁾ When S/P switch is set to parallel, it is not possible to trim output voltage.

Output Data

Line regulation	± 0.5%	Hold up time	
Load regulation		Vi= 115VAC	25ms
Non parallel model	±1%	Vi=230VAC	30ms
Parallel model	±5%	Voltage fall time (I_onom Vi nom)	150ms max
Minimum load	0A	Rated continuous loading	
Turn on time (full resistive load)		24V Model	20A @ 24VDC/16.8A @ 28.5VDC
Vi nom, Io nom	1000ms	48V Model	2.1A @ 48VDC/8.5A @ 56VDC
Vi nom, Io nom with 7000 µF CAP	1500ms	Reverse voltage	
Transient recovery time	2ms	24V Model	VDC 35
Ripple and noise	100mVpp	48V Model	VDC 63
Output voltage accuracy	±1%	Capacitor load	7000µF
Temperature coefficient	±0.03%/°C	Voltage rise time	
		Vi nom Io nom	150ms
		Vi nom, Io nom with 7000µF CAP	500ms

Input Data

Rated input voltage	115 - 230VAC		Power dissipation		
Voltage range			(Vi : 400VAC, Io nom)	24V Model	63W
AC	90 - 264VAC		48V Model	560W	
DC	120 - 375VDC		Frequency range	47-63Hz	
Rated input current			Leakage current		
(Vi:90VAC, Io nom)	Typ.	4.9/2.5A	Input-Output	0.25mA	
	Max.	7/3.5A	Input-FG	3.5mA	
Inrush current			P.F.C Vi=115/230VAC, Ionom	0.99/0.97	
	Vi= 115VAC	25A			
	Vi= 230VAC	50A			

Controls and Protections

Overload	110 - 140%	Over voltage protection	125/140%
Input fuse	T10A/250VAC internal	Internal surge voltage protection	Varistor
Output short circuit	Fold forward	(IEC 61000-4-5)	
Power ready output threshold at start up	≥17.6-19.4VDC		
Electrical isolation	500VDC		
Contact rating at 60VDC	0.3A		

General Data (@ nominal line, full load, 25°C)

Ambient temperature	-40°C to +71°C	MTB (Bellcore issue 6 @ 40°C, GB)	
Derating (>61°C to +71°C)	2.5%/C	24V Model	403000 Hours
Ambient humidity	20 ~ 95%RH	48V Model	416000 Hours
Storage	-40°C to +85°C	Case material	Metal
Protection degree	IP20	Dimensions LxWxD mm (inch)	124.5(4.9)x175.5(6.91)x123.6(4.87)
Cooling	Free air convection	Weight	430 g
Pollution degree	2		

Norms and Standards

Vibration resistance	meet IEC 60068-2-6 (Mounting by rail: 10-500Hz, 2G, along X, Y, Z each Axis, 60 min for each Axis)	CE	EN 61000-6-3, EN 55022 Class B, EN 61000-3-2, EN 61000-3-3, EN 61000-6-2, EN 55024, EN 61000-4-2 Level 4, EN 61000-4-3 Level 3, EN 61000-4-4 Level 4, EN 61000-4-5 L-Level 3, L/N-FG Level 4, EN 61000-4-6 Level 3, EN 61000-4-8 Level 4, EN 61000-4-11, ENV 50204 Level 2, EN 61204-3
Shock resistance	meet IEC 60068-2-27 (15G,11ms, 3 Axis, 6 faces, 3 times for each face)		
UL/cUL	UL508 listed, UL60950-1, UL1310 Class 2 Power Recognized		
TUV	EN 60950-1, CB scheme EN 61558-1, EN 61558-2- 17 (meet EN 60204)		

Block Diagram

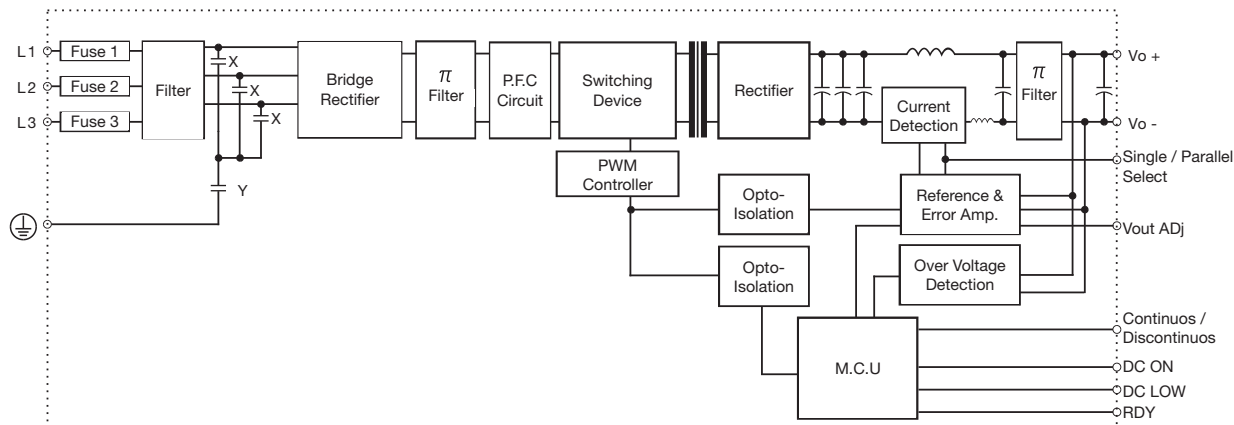

Pin Assignment and Front Controls

Pin No.	Designation	Description
1, 2	V-	Negative output terminal
3, 4	V+	Positive output terminal
5	RDY	A normal open relay contact for DC ON level control
6		(Never connect except 24V model)
7	L	Input terminals (phase conductor, no polarity at DC input)
8	N	Input terminal (neutral conductor, no polarity at DC input)
9		Ground this terminal to minimize high-frequency emissions
	DC ON	Operation indicator LED
	DC LOW	DC LOW voltage indicator LED
	Vout ADJ	Trimmer-potentiometer for Vout adjustment
	S/P	Single / Paralle select switch

Derating Diagram

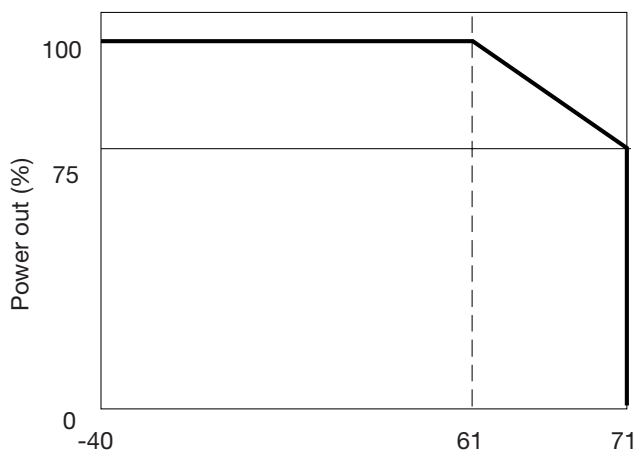

Typ. Efficiency Curve

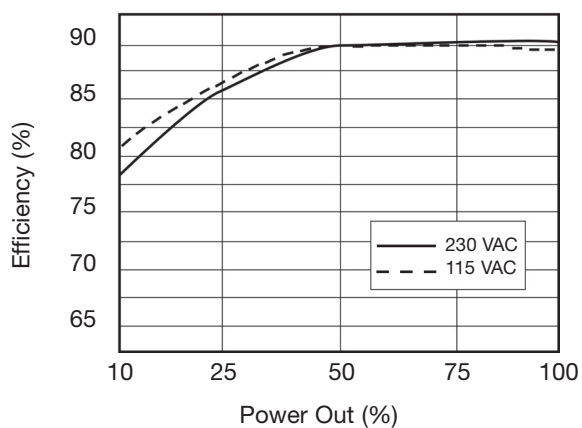

Typ. Current Limited Curve

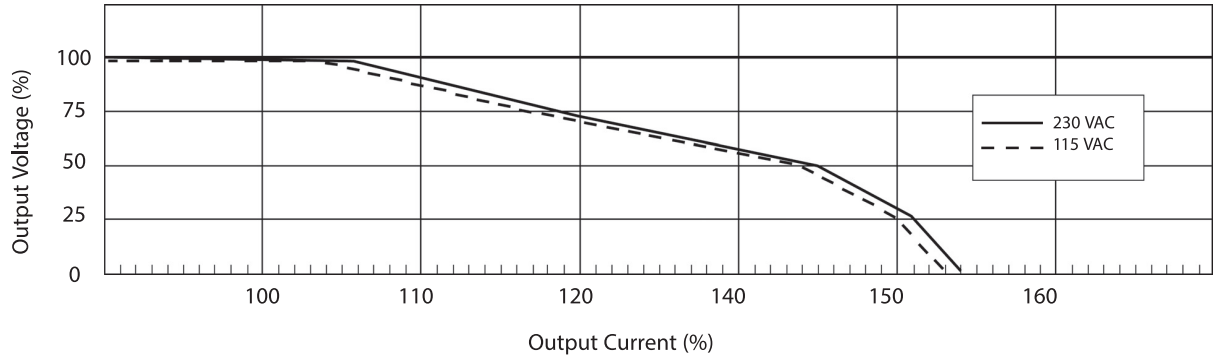

Mechanical Drawings mm (inches)

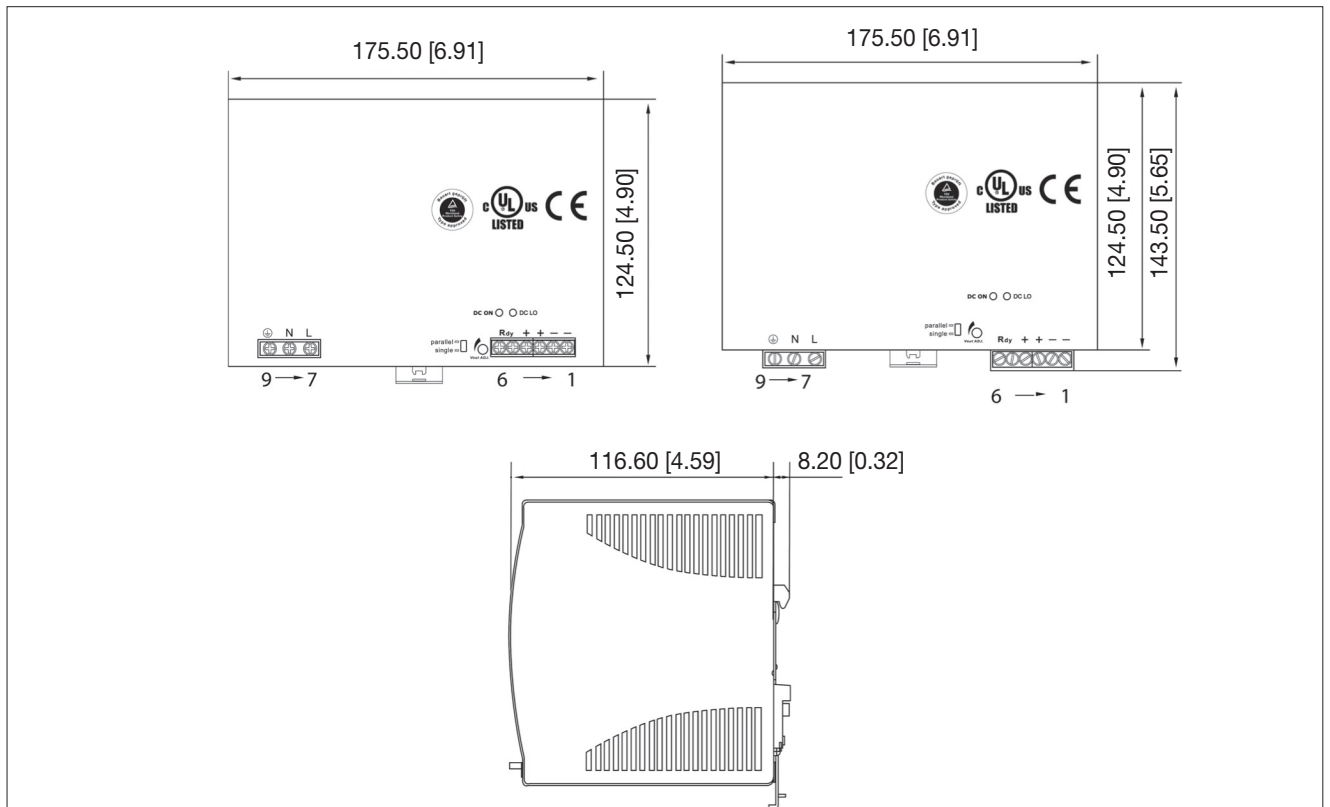

Installation

Ventilation and cooling

Normal convection
 All sides 25mm free space for cooling is recommended.

Connector

Size range AWG 24-10 (0.2~4mm²) flexible/solid cable.

Input Connector

can withstand torque at maximum 9 pound-inches

Output Connector

can withstand torque at maximum 5.5 pound-inches. 8 mm strip ping at cable end recommends, use copper conductors only, 60/75°C.

Max. torque for screws terminals

Input terminals
 Output terminals

0.784Nm (7.0lb-in)
 0.784Nm (7.0lb-in)